



For help visit [incyt by LX](https://incyt.io/support)
incyt.io/support

Copyright 2021 LX Corporation Pty Ltd. All rights reserved.

Apple and the Apple Logo are trademarks of Apple Inc., registered in the U.S. and other countries. App Store is a service mark of Apple Inc., registered in the U.S. and other countries.

Google Play and the Google Play logo are trademarks of Google Inc.

- **Temperature**

The recommended temperature range of this device is 5°C to 50°C. Use outside of this range may limit the device performance and functionality, and may reduce the battery and operational life of the device.

- **Wireless network**

This device uses multiple technologies for geo-location and communication with the Incyt platform. Installing the device in a location with unobstructed visibility to the devices that it will connect to, unobstructed visibility to the sky/GPS satellites, and strong cellular connectivity will ensure maximum performance and accuracy of the device.

- 12 Roughen smooth surfaces using a scouring pad or steel wool before application. Clean the mounting surface prior to installation by removing debris, and wiping using the alcohol wipe included.

- 13 Remove the VHB protective film, and press the device firmly against the mounting surface for 30 seconds to maximise adhesion.

Note: VHB adhesive will reach maximum bonding strength after 24 hours.

- 14 For installation scenarios where the device may encounter vibration, or be exposed to tampering, use security M4 pan head screws/bolts or rivets to secure as pictured on next page.

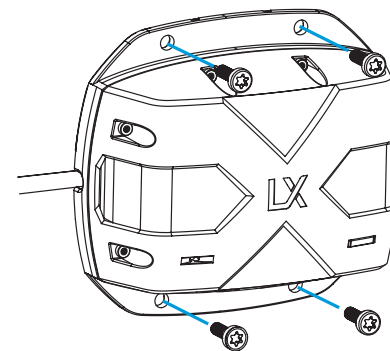

Product Overview

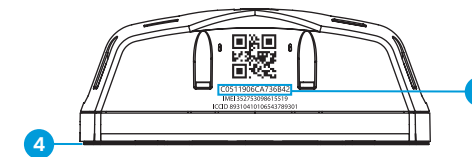
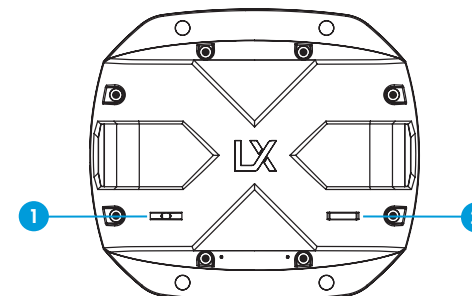

- 1 Environmental Sensing Port (Antares Sense model only)
- 2 LED
- 3 Device ID
- 4 VHB Tape



Antares
Quick Start Guide



Getting Started

- 1 Download the Incyt by LX app on the iOS AppStore, or Google Play store on your mobile device.



- 2 Create a new account or login with your existing account.
- 3 Follow instructions in the app to pair your device.
- 4 Follow the instructions on the next page to activate and mount your device.

Device Activation

This device requires external power to work. Power cables are available for purchase from [Incyt.io](https://www.incyt.io). Follow the steps below to power and activate the device:

- 5 Plug the connector on the power cable into the socket on the underside of the device, and screw the collar on the connector clockwise by hand to tighten as pictured below:

Note: Ensure the pins on the connector and the socket are aligned before inserting.

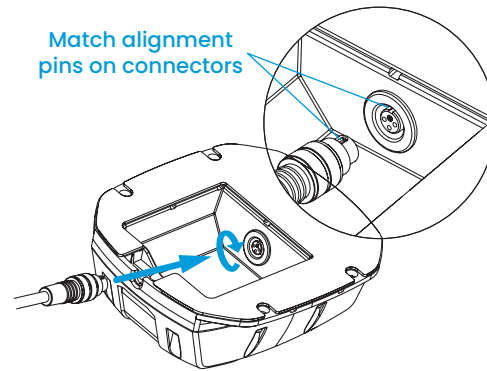

- 6 Connect the power cable to a suitable power source as in the example below. Detailed instructions are provided on the power cable packaging.



- 7 **Before activation, ensure the device is placed:**

- outside
- on a horizontal surface with an unobstructed view of the sky
- within LTE-M or NB-IoT network coverage, depending on your device configuration

- 8 Use the magnet included in the box to swipe over the LED on the device. The LED will start blinking white. Swipe a second time within 5 seconds. The LED will remain on for 5 seconds.

Note: If the LED turns ON for 3 seconds in a different colour, the device has already been activated.

- 9 The device will then attempt to connect to the Incyt platform for activation and configuration. This process, indicated by the LED blinking, may take several minutes. Once the device has successfully activated, the LED will remain white for 10 seconds and then turn off.
- 10 Refer to the Incyt app dashboard to ensure the device is connected.

Device Installation and Mounting

- 11 Select an appropriate location to mount your device. The most important factors to consider are:

- **Exposure to environment**

Although this device is rugged, protecting it from direct sunlight, rain, chemicals, and dirt will extend its operational life. The environmental sensing port needs to be kept clean, dry and unobstructed to provide accurate sensor readings.

- **Orientation**

See the diagram below for the mounting orientations of your specific device model:

